



NSAI
Standards

Irish Standard
I.S. EN 15969-2:2017

Tanks for transport of dangerous goods -
Digital interface for the data transfer
between tank vehicle and with stationary
facilities - Part 2: Commercial and logistic
data

I.S. EN 15969-2:2017

Incorporating amendments/corrigenda/National Annexes issued since publication:

The National Standards Authority of Ireland (NSAI) produces the following categories of formal documents:

I.S. xxx: Irish Standard — national specification based on the consensus of an expert panel and subject to public consultation.

S.R. xxx: Standard Recommendation — recommendation based on the consensus of an expert panel and subject to public consultation.

SWiFT xxx: A rapidly developed recommendatory document based on the consensus of the participants of an NSAI workshop.

This document replaces/revises/consolidates the NSAI adoption of the document(s) indicated on the CEN/CENELEC cover/Foreword and the following National document(s):

NOTE: The date of any NSAI previous adoption may not match the date of its original CEN/CENELEC document.

This document is based on:

EN 15969-2:2017

Published:

2017-12-13

This document was published under the authority of the NSAI and comes into effect on:

2017-12-31

ICS number:

35.240.60

NOTE: If blank see CEN/CENELEC cover page

NSAI
1 Swift Square,
Northwood, Santry
Dublin 9

T +353 1 807 3800
F +353 1 807 3838
E standards@nsai.ie
W NSAI.ie

Sales:
T +353 1 857 6730
F +353 1 857 6729
W standards.ie

Údarás um Chaighdeáin Náisiúnta na hÉireann

National Foreword

I.S. EN 15969-2:2017 is the adopted Irish version of the European Document EN 15969-2:2017, Tanks for transport of dangerous goods - Digital interface for the data transfer between tank vehicle and with stationary facilities - Part 2: Commercial and logistic data

This document does not purport to include all the necessary provisions of a contract. Users are responsible for its correct application.

For relationships with other publications refer to the NSAI web store.

Compliance with this document does not of itself confer immunity from legal obligations.

In line with international standards practice the decimal point is shown as a comma (,) throughout this document.

This page is intentionally left blank

EUROPEAN STANDARD

EN 15969-2

NORME EUROPÉENNE

EUROPÄISCHE NORM

December 2017

ICS 35.240.60

Supersedes EN 15969-2:2011

English Version

Tanks for transport of dangerous goods - Digital interface for the data transfer between tank vehicle and with stationary facilities - Part 2: Commercial and logistic data

Citernes destinées au transport de matières
dangereuses - Interface numérique pour le transfert de
données entre des véhicules-citernes et des
installations fixes - Partie 2: Données commerciales et
logistiques

Tanks für die Beförderung gefährlicher Güter - Digitale
Schnittstelle für den Datenaustausch zwischen
Tankfahrzeugen und stationären Einrichtungen - Teil
2: Kommerzielle und logistische Daten

This European Standard was approved by CEN on 15 October 2017.

CEN members are bound to comply with the CEN/CENELEC Internal Regulations which stipulate the conditions for giving this European Standard the status of a national standard without any alteration. Up-to-date lists and bibliographical references concerning such national standards may be obtained on application to the CEN-CENELEC Management Centre or to any CEN member.

This European Standard exists in three official versions (English, French, German). A version in any other language made by translation under the responsibility of a CEN member into its own language and notified to the CEN-CENELEC Management Centre has the same status as the official versions.

CEN members are the national standards bodies of Austria, Belgium, Bulgaria, Croatia, Cyprus, Czech Republic, Denmark, Estonia, Finland, Former Yugoslav Republic of Macedonia, France, Germany, Greece, Hungary, Iceland, Ireland, Italy, Latvia, Lithuania, Luxembourg, Malta, Netherlands, Norway, Poland, Portugal, Romania, Serbia, Slovakia, Slovenia, Spain, Sweden, Switzerland, Turkey and United Kingdom.



EUROPEAN COMMITTEE FOR STANDARDIZATION
COMITÉ EUROPÉEN DE NORMALISATION
EUROPÄISCHES KOMITEE FÜR NORMUNG

CEN-CENELEC Management Centre: Avenue Marnix 17, B-1000 Brussels

EN 15969-2:2017 (E)

Contents		Page
European foreword		3
Introduction		5
1	Scope	7
2	Normative references	7
3	Terms and definitions	7
4	Files	8
4.1	Format identifiers	8
4.2	Relations	9
4.3	File naming conventions	10
5	Fields of special types	11
5.1	Text module reference	11
5.2	Geo-Coordinates	11
5.3	UTF-8 strings	11
6	Price calculation rules	12
6.1	General	12
6.2	Low volume (surcharge)	12
6.3	Pricing of packed products, container, pieces	12
6.4	Taxes	13
7	Description of tour management	13
7.1	Handling of several tours	13
7.2	Handling of a pseudo-tour with a pool of orders	13
7.3	Handling of orders	13
7.4	Handling of products	14
8	Fields and records of RC_File	14
9	Multi-Order Data (Subnode RC_FILE)	38
9.1	General	38
9.2	Node RC_File	38
9.3	Information concerning application	39

European foreword

This document (EN 15969-2:2017) has been prepared by Technical Committee CEN/TC 296 “Tanks for the transport of dangerous goods”, the secretariat of which is held by AFNOR.

This European Standard shall be given the status of a national standard, either by publication of an identical text or by endorsement, at the latest by June 2018, and conflicting national standards shall be withdrawn at the latest by June 2018.

Attention is drawn to the possibility that some of the elements of this document may be the subject of patent rights. CEN shall not be held responsible for identifying any or all such patent rights.

This document supersedes EN 15969-2:2011.

With regard to EN 15969-2:2011 the following fundamental changes are given:

- fields for air craft refilling added.

Recipients of this draft are invited to submit, with their comments, notification of any relevant patent rights of which they are aware and to provide supporting documentation.

EN 15969, *Tanks for transport of dangerous goods — Digital interface for the data transfer between tank vehicle and with stationary facilities*, consists of 2 parts:

- *Part 1: Protocol specification — Control, measurement and event data;*
- *Part 2: Commercial and logistic data.*

This European Standard forms part of a coherent standards programme comprising the following standards:

- EN 13616-1, *Overfill prevention devices for static tanks for liquid fuels — Part 1: Overfill prevention devices with closure device;*
- EN 13616-2, *Overfill prevention devices for static tanks for liquid fuels — Part 2: Overfill prevention devices without a closure device;*
- EN 13922, *Tanks for transport of dangerous goods — Service equipment for tanks — Overfill prevention systems for liquid fuels;*
- EN 14116, *Tanks for transport of dangerous goods — Digital interface for product recognition devices for liquid fuels;*
- EN 15207, *Tanks for the transport of dangerous goods — Plug/socket connection and supply characteristics for service equipment in hazardous areas with 24 V nominal supply voltage;*
- EN 15208, *Tanks for transport of dangerous goods — Sealed parcel delivery systems — Working principles and interface specifications;*
- EN 15969-1, *Tanks for transport of dangerous goods — Digital interface for the data transfer between tank vehicle and with stationary facilities — Part 1: Protocol specification - Control, measurement and event data.*

EN 15969-2:2017 (E)

According to the CEN/CENELEC Internal Regulations, the national standards organizations of the following countries are bound to implement this European Standard: Austria, Belgium, Bulgaria, Croatia, Cyprus, Czech Republic, Denmark, Estonia, Finland, Former Yugoslav Republic of Macedonia, France, Germany, Greece, Hungary, Iceland, Ireland, Italy, Latvia, Lithuania, Luxembourg, Malta, Netherlands, Norway, Poland, Portugal, Romania, Serbia, Slovakia, Slovenia, Spain, Sweden, Switzerland, Turkey and the United Kingdom.

Introduction

FTL is an acronym for **Fuel Truck Link**, the interface between electronic system(s) on board of a tank truck (Tank-Vehicle-Equipment) and any external computer, Part 2 mainly for a host installed in the office and connected via Internet (TCP/IP); for illustration, see Figure 1.

This European Standard specifies data format for all interconnecting communication paths for commercial issues.

This European Standard offers the user following features:

- multiple orders (batch processing);
- pricing;
- master data (e.g. products, customers, drivers, taxes);
- additional texts for the printout;
- information for the drivers;
- tour management;
- data for invoicing with surcharge;
- data for delivery packaged goods;
- handle planned and unplanned deliveries.

EN 15969-2:2017 (E)

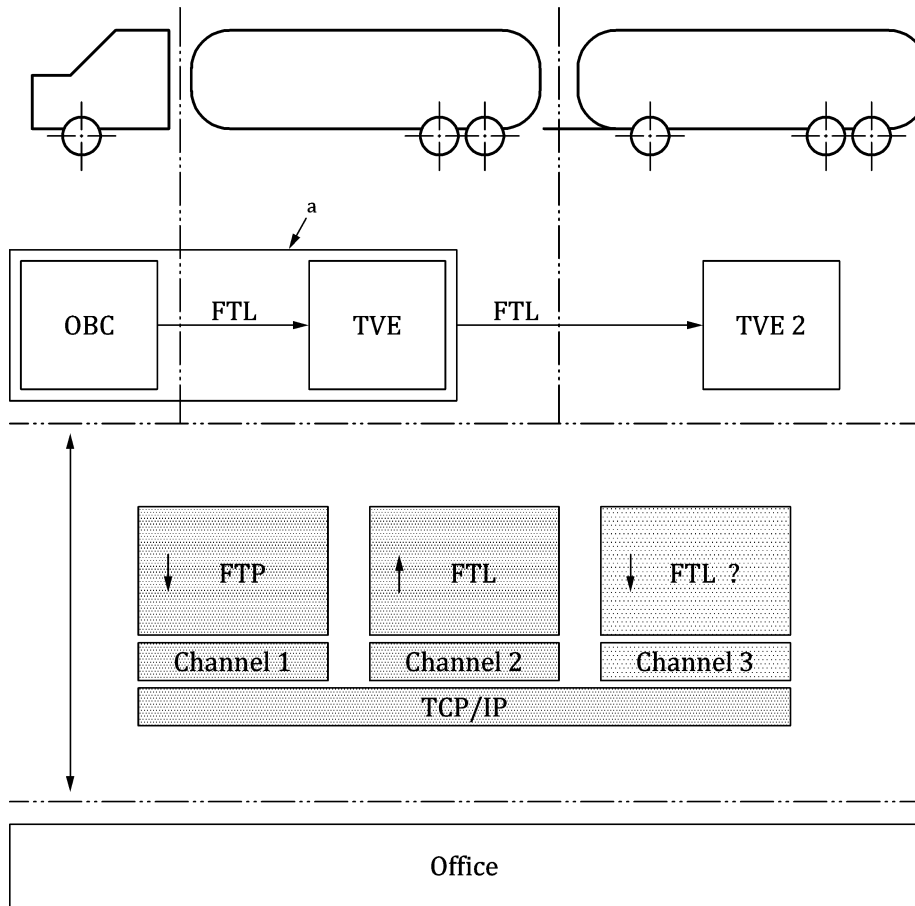

Key

→ direction of communication (client → server)

a may be either two independent units or one single unit which incorporates both functions OBC and TVE

Figure 1 — Communication structure

1 Scope

This European Standard specifies the data structure needed for tour management, scheduling orders of measured and unmeasured products online to the truck. Processed orders are transferred back to the host in the office at once or later every time the truck is online.

It specifies the transfer of commercial and logistic data between transport vehicle equipment, on board computer of the tank vehicle and stationary facilities for all communication channels between these parties.

This document should only be used in conjunction with EN 15969-1 and should not modify or override any of the requirements of EN 15969-1.

2 Normative references

The following documents, in whole or in part, are normatively referenced in this document and are indispensable for its application. For dated references, only the edition cited applies. For undated references, the latest edition of the referenced document (including any amendments) applies.

EN 14116, *Tanks for transport of dangerous goods — Digital interface for product recognition devices for liquid fuels*

EN 15969-1:2017, *Tanks for transport of dangerous goods — Digital interface for the data transfer between tank vehicle and with stationary facilities — Part 1: Protocol specification — Control, measurement and event data*

EN ISO 3166-1, *Codes for the representation of names of countries and their subdivisions — Part 1: Country codes (ISO 3166-1)*

ISO 639-1, *Codes for the representation of names of languages — Part 1: Alpha-2 code*

ISO 4217, *Codes for the representation of currencies*

ISO/IEC 10646:2014, *Information technology — Universal Coded Character Set (UCS)*

3 Terms and definitions

For the purposes of this document, the terms and definitions given in EN 15969-1:2017 and the following apply.

3.1

dispatcher

person who manages tour at the host system

3.2

operator

driver

person who operates the truck and the truck management computer

3.3

tour

set of at least one 'Order Record' and related records, which describes a collection of stops at different customers and the ordered products, so that the driver knows where to go and what to deliver

This is a free preview. Purchase the entire publication at the link below:

[Product Page](#)

-
- [Looking for additional Standards? Visit Intertek Inform Infostore](#)
 - [Learn about LexConnect, All Jurisdictions, Standards referenced in Australian legislation](#)
-