



NSAI
Standards

Irish Standard
I.S. EN ISO 12822:2020

Glass packaging - 26 H 126 crown finish - Dimensions (ISO 12822:2020)

I.S. EN ISO 12822:2020

Incorporating amendments/corrigenda/National Annexes issued since publication:

The National Standards Authority of Ireland (NSAI) produces the following categories of formal documents:

I.S. xxx: Irish Standard — national specification based on the consensus of an expert panel and subject to public consultation.

S.R. xxx: Standard Recommendation — recommendation based on the consensus of an expert panel and subject to public consultation.

SWiFT xxx: A rapidly developed recommendatory document based on the consensus of the participants of an NSAI workshop.

This document replaces/revises/consolidates the NSAI adoption of the document(s) indicated on the CEN/CENELEC cover/Foreword and the following National document(s):

NOTE: The date of any NSAI previous adoption may not match the date of its original CEN/CENELEC document.

This document is based on:

EN ISO 12822:2020

Published:

2020-04-01

This document was published under the authority of the NSAI and comes into effect on:

2020-04-19

ICS number:

55.100

NOTE: If blank see CEN/CENELEC cover page

NSAI
1 Swift Square,
Northwood, Santry
Dublin 9

T +353 1 807 3800
F +353 1 807 3838
E standards@nsai.ie
W NSAI.ie

Sales:
T +353 1 857 6730
F +353 1 857 6729
W standards.ie

Údarás um Chaighdeáin Náisiúnta na hÉireann

National Foreword

I.S. EN ISO 12822:2020 is the adopted Irish version of the European Document EN ISO 12822:2020, Glass packaging - 26 H 126 crown finish - Dimensions (ISO 12822:2020)

This document does not purport to include all the necessary provisions of a contract. Users are responsible for its correct application.

For relationships with other publications refer to the NSAI web store.

Compliance with this document does not of itself confer immunity from legal obligations.

In line with international standards practice the decimal point is shown as a comma (,) throughout this document.

This page is intentionally left blank

EUROPEAN STANDARD

EN ISO 12822

NORME EUROPÉENNE

EUROPÄISCHE NORM

April 2020

ICS 55.100

Supersedes EN 14635:2010

English Version

Glass packaging - 26 H 126 crown finish - Dimensions (ISO 12822:2020)

Emballages en verre - Bague couronne 26 H 126 -
Dimensions (ISO 12822:2020)

Verpackungen aus Glas - Kronenmundstück 26 H 126 -
Maße (ISO 12822:2020)

This European Standard was approved by CEN on 19 March 2020.

CEN members are bound to comply with the CEN/CENELEC Internal Regulations which stipulate the conditions for giving this European Standard the status of a national standard without any alteration. Up-to-date lists and bibliographical references concerning such national standards may be obtained on application to the CEN-CENELEC Management Centre or to any CEN member.

This European Standard exists in three official versions (English, French, German). A version in any other language made by translation under the responsibility of a CEN member into its own language and notified to the CEN-CENELEC Management Centre has the same status as the official versions.

CEN members are the national standards bodies of Austria, Belgium, Bulgaria, Croatia, Cyprus, Czech Republic, Denmark, Estonia, Finland, France, Germany, Greece, Hungary, Iceland, Ireland, Italy, Latvia, Lithuania, Luxembourg, Malta, Netherlands, Norway, Poland, Portugal, Republic of North Macedonia, Romania, Serbia, Slovakia, Slovenia, Spain, Sweden, Switzerland, Turkey and United Kingdom.



EUROPEAN COMMITTEE FOR STANDARDIZATION
COMITÉ EUROPÉEN DE NORMALISATION
EUROPÄISCHES KOMITEE FÜR NORMUNG

CEN-CENELEC Management Centre: Rue de la Science 23, B-1040 Brussels

EN ISO 12822:2020 (E)

Contents	Page
European foreword.....	3

European foreword

This document (EN ISO 12822:2020) has been prepared by Technical Committee ISO/TC 63 “Glass containers” in collaboration with Technical Committee CEN/TC 261 “Packaging” the secretariat of which is held by AFNOR.

This European Standard shall be given the status of a national standard, either by publication of an identical text or by endorsement, at the latest by October 2020, and conflicting national standards shall be withdrawn at the latest by October 2020.

Attention is drawn to the possibility that some of the elements of this document may be the subject of patent rights. CEN shall not be held responsible for identifying any or all such patent rights.

This document supersedes EN 14635:2010.

According to the CEN-CENELEC Internal Regulations, the national standards organizations of the following countries are bound to implement this European Standard: Austria, Belgium, Bulgaria, Croatia, Cyprus, Czech Republic, Denmark, Estonia, Finland, France, Germany, Greece, Hungary, Iceland, Ireland, Italy, Latvia, Lithuania, Luxembourg, Malta, Netherlands, Norway, Poland, Portugal, Republic of North Macedonia, Romania, Serbia, Slovakia, Slovenia, Spain, Sweden, Switzerland, Turkey and the United Kingdom.

Endorsement notice

The text of ISO 12822:2020 has been approved by CEN as EN ISO 12822:2020 without any modification.

This page is intentionally left blank

**INTERNATIONAL
STANDARD**

**ISO
12822**

Second edition
2020-03

**Glass packaging — 26 H 126 crown
finish — Dimensions**

Emballages en verre — Bague couronne 26 H 126 — Dimensions



Reference number
ISO 12822:2020(E)

© ISO 2020

ISO 12822:2020(E)



COPYRIGHT PROTECTED DOCUMENT

© ISO 2020

All rights reserved. Unless otherwise specified, or required in the context of its implementation, no part of this publication may be reproduced or utilized otherwise in any form or by any means, electronic or mechanical, including photocopying, or posting on the internet or an intranet, without prior written permission. Permission can be requested from either ISO at the address below or ISO's member body in the country of the requester.

ISO copyright office
CP 401 • Ch. de Blandonnet 8
CH-1214 Vernier, Geneva
Phone: +41 22 749 01 11
Fax: +41 22 749 09 47
Email: copyright@iso.org
Website: www.iso.org

Published in Switzerland

Contents

	Page
Foreword	iv
Introduction	v
1 Scope	1
2 Normative references	1
3 Terms and definitions	1
4 Dimensions	1
Bibliography	6

ISO 12822:2020(E)

Foreword

ISO (the International Organization for Standardization) is a worldwide federation of national standards bodies (ISO member bodies). The work of preparing International Standards is normally carried out through ISO technical committees. Each member body interested in a subject for which a technical committee has been established has the right to be represented on that committee. International organizations, governmental and non-governmental, in liaison with ISO, also take part in the work. ISO collaborates closely with the International Electrotechnical Commission (IEC) on all matters of electrotechnical standardization.

The procedures used to develop this document and those intended for its further maintenance are described in the ISO/IEC Directives, Part 1. In particular, the different approval criteria needed for the different types of ISO documents should be noted. This document was drafted in accordance with the editorial rules of the ISO/IEC Directives, Part 2 (see www.iso.org/directives).

Attention is drawn to the possibility that some of the elements of this document may be the subject of patent rights. ISO shall not be held responsible for identifying any or all such patent rights. Details of any patent rights identified during the development of the document will be in the Introduction and/or on the ISO list of patent declarations received (see www.iso.org/patents).

Any trade name used in this document is information given for the convenience of users and does not constitute an endorsement.

For an explanation of the voluntary nature of standards, the meaning of ISO specific terms and expressions related to conformity assessment, as well as information about ISO's adherence to the World Trade Organization (WTO) principles in the Technical Barriers to Trade (TBT) see www.iso.org/iso/foreword.html.

This document was prepared by Technical Committee ISO/TC 63, *Glass containers*.

This second edition cancels and replaces the first edition (ISO 12822:2015), which has been technically revised.

The main changes compared to the previous edition are as follows:

- changes in [Figures 2, 3, 4](#) and [5](#);
- deletion of reference to the Cetie datasheet EC 1-02;
- “crown closure” and “crown cork” replaced by “crown cap”;
- editorial corrections.

Any feedback or questions on this document should be directed to the user's national standards body. A complete listing of these bodies can be found at www.iso.org/members.html.

Introduction

This document is based on Reference [1].

Efficient packaging is of great importance for the distribution and the protection of goods. Insufficient or inappropriate packaging can lead to damage or wastage of the contents of the pack.

Glass packaging — 26 H 126 crown finish — Dimensions

1 Scope

This document specifies the dimensions of the 26 mm-shallow crown finish for glass bottles containing beverages. The shallow crown finish is designed to use a metal crown cap (see Reference [2]).

2 Normative references

The following documents are referred to in the text in such a way that some or all of their content constitutes requirements of this document. For dated references, only the edition cited applies. For undated references, the latest edition of the referenced document (including any amendments) applies.

ISO 9058, *Glass containers — Standard tolerances for bottles*

3 Terms and definitions

No terms and definitions are listed in this document.

ISO and IEC maintain terminological databases for use in standardization at the following addresses:

- ISO Online browsing platform: available at <https://www.iso.org/obp>
- IEC Electropedia: available at <http://www.electropedia.org/>

4 Dimensions

The design and dimensions of the finish shall be as shown in [Figure 1](#) to [Figure 5](#).

Details which are not specified shall be selected in accordance with the application.

The general tolerances shall be in accordance with ISO 9058.

Dimensions in millimetres

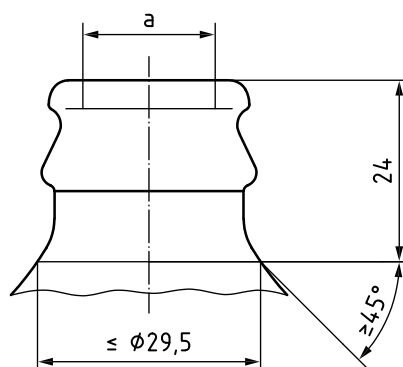

Key

- ^a \varnothing between 18,5 max and 17 min measured at 3 mm max down from the top, see key d in [Figures 4](#) and [5](#) minimum through \varnothing bore 15,5 m.

Figure 1 — Shoulder and bore dimensions

This is a free preview. Purchase the entire publication at the link below:

[Product Page](#)

-
- [Looking for additional Standards? Visit Intertek Inform Infostore](#)
 - [Learn about LexConnect, All Jurisdictions, Standards referenced in Australian legislation](#)
-