



National Standards Authority of Ireland

IRISH STANDARD

I.S. EN 15010:2006

ICS 55.130

**AEROSOL CONTAINERS - ALUMINIUM
CONTAINERS - TOLERANCES OF THE
FUNDAMENTAL DIMENSIONS IN
CONNECTION WITH THE CLINCH**

National Standards
Authority of Ireland
Glasnevin, Dublin 9
Ireland

Tel: +353 1 807 3800
Fax: +353 1 807 3838
<http://www.nsai.ie>

Sales
<http://www.standards.ie>

*This Irish Standard was
published under the
authority of the National
Standards Authority of
Ireland and comes into
effect on:*

20 November 2006

**NO COPYING WITHOUT NSAI
PERMISSION EXCEPT AS
PERMITTED BY COPYRIGHT
LAW**

© NSAI 2006

Price Code D

Údarás um Chaighdeán Náisiúnta na hÉireann

EUROPEAN STANDARD

EN 15010

NORME EUROPÉENNE

EUROPÄISCHE NORM

October 2006

ICS 55.130

English Version

Aerosol containers - Aluminium containers - Tolerances of the fundamental dimensions in connection with the clinch

Réipients pour aérosols - Réipients en aluminium -
Tolérances des dimensions de base en rapport avec le
dudgeonnage

Aerosolpackungen - Aluminiumbehälter - Toleranzen der
Grundmaße im Zusammenhang mit dem Clinch

This European Standard was approved by CEN on 6 August 2006.

CEN members are bound to comply with the CEN/CENELEC Internal Regulations which stipulate the conditions for giving this European Standard the status of a national standard without any alteration. Up-to-date lists and bibliographical references concerning such national standards may be obtained on application to the Central Secretariat or to any CEN member.

This European Standard exists in three official versions (English, French, German). A version in any other language made by translation under the responsibility of a CEN member into its own language and notified to the Central Secretariat has the same status as the official versions.

CEN members are the national standards bodies of Austria, Belgium, Cyprus, Czech Republic, Denmark, Estonia, Finland, France, Germany, Greece, Hungary, Iceland, Ireland, Italy, Latvia, Lithuania, Luxembourg, Malta, Netherlands, Norway, Poland, Portugal, Romania, Slovakia, Slovenia, Spain, Sweden, Switzerland and United Kingdom.



EUROPEAN COMMITTEE FOR STANDARDIZATION
COMITÉ EUROPÉEN DE NORMALISATION
EUROPÄISCHES KOMITEE FÜR NORMUNG

Management Centre: rue de Stassart, 36 B-1050 Brussels

EN 15010:2006 (E)

Foreword

This document (EN 15010:2006) has been prepared by Technical Committee CEN/TC 261 "Packaging", the secretariat of which is held by AFNOR.

This European Standard shall be given the status of a national standard, either by publication of an identical text or by endorsement, at the latest by April 2007, and conflicting national standards shall be withdrawn at the latest by April 2007.

This draft European Standard is one of a series of thirteen related standards with the following titles:

- EN 14847, *Aerosol containers — Tinplate containers — Dimensions of the 25,4 mm aperture*
- EN 14848, *Aerosol containers — Metal containers with 25,4 mm aperture — Dimensions of valve cups*
- EN 14849, *Aerosol containers — Glass containers — Dimensions of aerosol valve ferrules*
- EN 14850, *Aerosol containers — Metal containers with 25,4 mm aperture — Measurement of contact height*
- EN 14851, *Aerosol containers — Aerosol foam flammability test*
- EN 14852, *Aerosol containers — Determination of the ignition distance of the spray jet*
- EN 14853, *Aerosol containers — Enclosed space ignition test*
- EN 14854, *Aerosol containers — Glass containers — Dimensions of the neck finish*
- EN 15006, *Metal aerosol containers — Aluminium containers — Dimensions of the 25,4 mm aperture*
- EN 15007, *Metal aerosol containers — Tinplate containers — Dimensions of two and three-piece cans*
- EN 15008, *Aerosol containers — Aluminium containers — Dimensions of one-piece cans with 25,4 mm aperture*
- EN 15009, *Aerosol containers — Compartmented aerosol containers*
- EN 15010, *Aerosol containers — Aluminium containers — Tolerances of the fundamental dimensions in connection with the clinch*

According to the CEN/CENELEC Internal Regulations, the national standards organizations of the following countries are bound to implement this European Standard: Austria, Belgium, Cyprus, Czech Republic, Denmark, Estonia, Finland, France, Germany, Greece, Hungary, Iceland, Ireland, Italy, Latvia, Lithuania, Luxembourg, Malta, Netherlands, Norway, Poland, Portugal, Romania, Slovakia, Slovenia, Spain, Sweden, Switzerland and United Kingdom.

Introduction

The dimensions given in this standard, while not binding in any respect, represent good practice for can manufacturers as agreed within Europe, between suppliers and fillers.

The specific dimensions of 25,4 mm aperture aluminium aerosol containers given in this standard are recognised as critical in respect of closure efficiency, and as such they are of considerable importance both for the can manufacturer in process control and to the filler for inward goods inspection and ultimately swage setting and control.

EN 15010:2006 (E)

1 Scope

This European Standard defines the critical dimensions of the location of the 25,4 mm aperture relative to the base of aerosol cans for clinching with valve cups.

The specification of the fundamental dimensions in this standard, relates to all 25,4 mm aperture aluminium and aluminium alloy cans, irrespective of size, shape and mode of manufacture; whose dimensions and tolerances fall within the dimensional scope of EN 15008.

2 Requirements

The tolerances for parallelism, eccentricity and height shall be as shown in Figure 1.

NOTE 1 Eccentricity (see A): the maximum allowed eccentricity is independent of the height.

NOTE 2 Parallelism (see B): the parallelism is measured from the upper surface of the bead. Lower tolerances apply if flowed in gaskets are used.

NOTE 3 Height (see H): smaller values for the height tolerance may be agreed in special cases.

All dimensions in millimetres

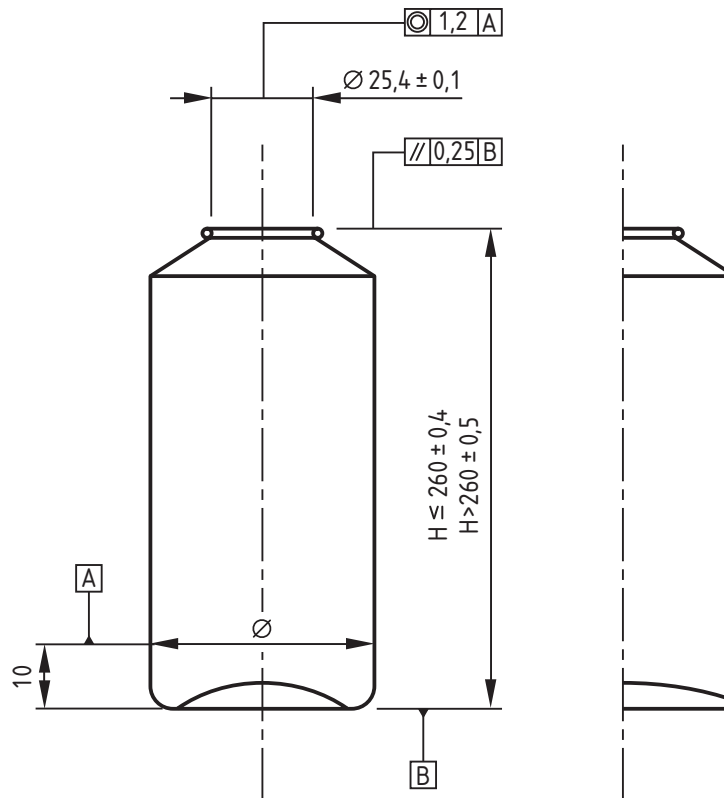

Figure 1 — Tolerances for eccentricity, parallelism and height

This is a free preview. Purchase the entire publication at the link below:

[Product Page](#)

-
- [Looking for additional Standards? Visit Intertek Inform Infostore](#)
 - [Learn about LexConnect, All Jurisdictions, Standards referenced in Australian legislation](#)
-