



National Standards Authority of Ireland

IRISH STANDARD

I.S. EN 50377-8-4:2007

ICS 33.180.20

**CONNECTOR SETS AND INTERCONNECT
COMPONENTS TO BE USED IN OPTICAL
FIBRE COMMUNICATION SYSTEMS -
PRODUCT SPECIFICATIONS -- PART 8-4:
LSH-APC SIMPLEX TERMINATED ON IEC
60793-2-50 CATEGORY B1.1 AND B1.3
SINGLEMODE FIBRE, COMPOSITE
FERRULE CATEGORY U**

National Standards
Authority of Ireland
Glasnevin, Dublin 9
Ireland

Tel: +353 1 807 3800
Fax: +353 1 807 3838
<http://www.nσαι.ie>

Sales
<http://www.standards.ie>

*This Irish Standard was
published under the authority
of the National Standards
Authority of Ireland and
comes into effect on:
2 October 2007*

**NO COPYING WITHOUT NSAI
PERMISSION EXCEPT AS
PERMITTED BY COPYRIGHT
.....**

© NSAI 2007

Price Code L

Údarás um Chaighdeáin Náisiúnta na hÉireann

This page is intentionally left BLANK.

EUROPEAN STANDARD
NORME EUROPÉENNE
EUROPÄISCHE NORM

EN 50377-8-4

August 2007

ICS 33.180.20

English version

**Connector sets and interconnect components
to be used in optical fibre communication systems -
Product specifications -
Part 8-4: LSH-APC simplex terminated on IEC 60793-2-50
category B1.1 and B1.3 singlemode fibre,
composite ferrule category U**

Jeux de connecteurs et composants
d'interconnexion à utiliser
dans les systèmes de communication
par fibres optiques -
Spécifications de produit -
Partie 8-4: Type LSH-APC simplex câblé
sur une fibre unimodale des catégories
B1.1 et B1.3 de la CEI 60793-2-50,
ferrule composite, catégorie U

Steckverbindersätze
und Verbindungselemente
für Lichtwellenleiter-
Datenübertragungssysteme -
Produktnormen -
Teil 8-4: Bauart LSH-APC-Simplex zum
Anschluss an Einmodenfasern der Typen
B1.1 und B1.3 nach IEC 60793-2-50
mit Komposit-Stift für die Kategorie U

This European Standard was approved by CENELEC on 2007-03-01. CENELEC members are bound to comply with the CEN/CENELEC Internal Regulations which stipulate the conditions for giving this European Standard the status of a national standard without any alteration.

Up-to-date lists and bibliographical references concerning such national standards may be obtained on application to the Central Secretariat or to any CENELEC member.

This European Standard exists in three official versions (English, French, German). A version in any other language made by translation under the responsibility of a CENELEC member into its own language and notified to the Central Secretariat has the same status as the official versions.

CENELEC members are the national electrotechnical committees of Austria, Belgium, Bulgaria, Cyprus, the Czech Republic, Denmark, Estonia, Finland, France, Germany, Greece, Hungary, Iceland, Ireland, Italy, Latvia, Lithuania, Luxembourg, Malta, the Netherlands, Norway, Poland, Portugal, Romania, Slovakia, Slovenia, Spain, Sweden, Switzerland and the United Kingdom.

CENELEC

European Committee for Electrotechnical Standardization
Comité Européen de Normalisation Electrotechnique
Europäisches Komitee für Elektrotechnische Normung

Central Secretariat: rue de Stassart 35, B - 1050 Brussels

Foreword

This European Standard was prepared by the Technical Committee CENELEC TC 86BXA, Fibre optic interconnect, passive and connectorised components.

The text of the draft was submitted to the Unique Acceptance Procedure and was approved by CENELEC as EN 50377-8-4 on 2007-03-01.

The following dates were fixed:

- latest date by which the EN has to be implemented
at national level by publication of an identical
national standard or by endorsement (dop) 2008-03-01
 - latest date by which the national standards conflicting
with the EN have to be withdrawn (dow) 2010-03-01
-

**Connector sets and interconnect components to be used in optical fibre communication systems -
Product specifications**

Part 8-4: LSH-APC simplex terminated on IEC 60793-2-50 category B1.1 and B1.3 singlemode fibre, composite ferrule category U

Coupling mechanism:	Description Latched push-pull	Application:	Performance For use in category U (Uncontrolled environment)
Configuration:	Plug/adaptor/plug	Attenuation grades: (Random mate)	B: $\leq 0,12$ dB mean $\leq 0,25$ dB for > 97 % of measurements C: $\leq 0,25$ dB mean $\leq 0,50$ dB for > 97 % of measurements
Fibre category:	EN 60793-2-50 Types B1.1 and B1.3		
Cable type:	See Table 3	Return loss grades:	1: ≥ 60 dB (mated) ≥ 55 dB(unmated)

Related documents:

EN 60794-2	Optical fibre cables - Part 2: Indoor cables - Sectional specification (IEC 60794-2)
EN 61300 series	Fibre optic interconnecting devices and passive components - Basic test and measurement procedures (IEC 61300 series)
EN 61753-1	Fibre optic interconnecting devices and passive components performance standard - Part 1: General and guidance for performance standards (IEC 61753-1)
EN 61754-15	Fibre optic connector interfaces - Part 15: Type LSH connector family (IEC 61754-15)
EN 61755-1	Fibre optic connector optical interfaces - Part 1: Optical interfaces for single mode non-dispersion shifted fibres - General and guidance (IEC 61755-1)
EN 61755-3-6	Fibre optic connector optical interfaces - Part 3-6: Optical interface - 2,5 mm and 1,25 mm diameter cylindrical 8 degrees angled-PC composite ferrule using Cu-Ni-alloy as fibre surrounding material, single mode fibre (IEC 61755-3-6)
ETSI TS 100 671	Transmission and Multiplexing (TM); Passive optical components; Optical fibre connectors for single-mode optical fibre communication systems; Common requirements and conformance testing

Outline and maximum dimensions:

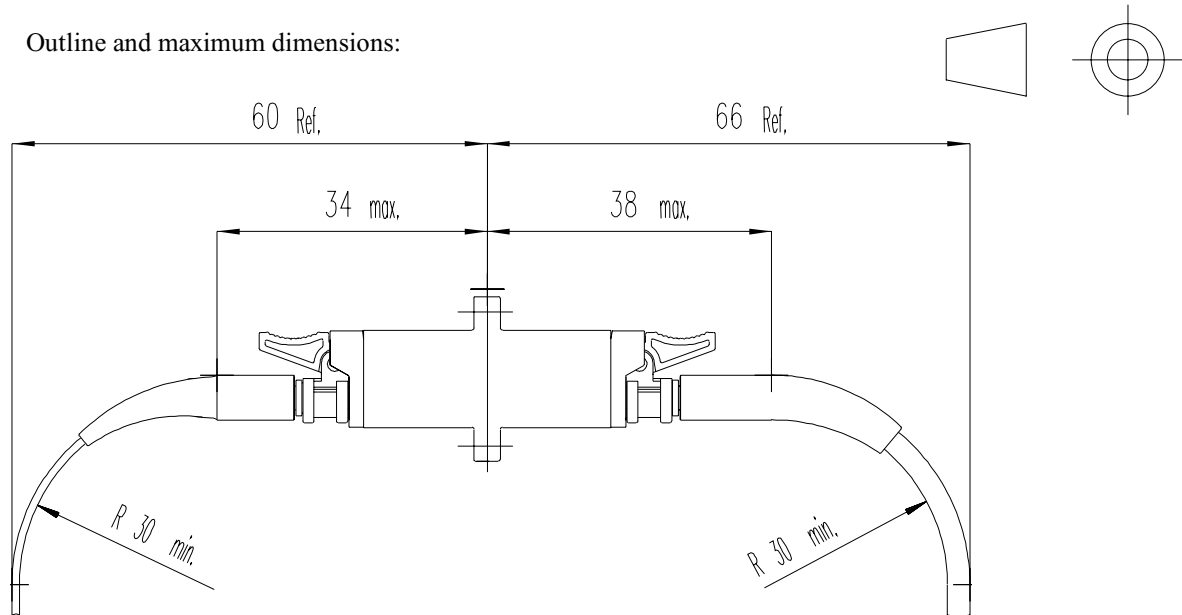

Contents

1	Scope	5
1.1	Product definition	5
1.2	Intermateability	5
1.3	Operating environment	5
1.4	Reliability.....	5
1.5	Quality assurance	5
2	Normative references	6
3	Description	7
3.1	Plug.....	7
3.2	Adaptor.....	7
3.3	Materials.....	7
3.4	Dimensions	7
3.5	Colour and marking	8
4	Variants	9
4.1	Terminated plug.....	9
4.2	Adaptor.....	9
5	Dimensional requirements	11
5.1	Outline dimensions.....	11
5.2	Mating face and other limit dimensions	15
6	Tests	24
6.1	Sample size	24
6.2	Test and measurement methods	24
6.3	Test sequence.....	24
6.4	Pass/fail criteria.....	24
7	Test report	24
8	Testing requirements	25
8.1	Dimensional and marking requirements	25
8.2	Optical performance requirements.....	25
8.3	Mechanical performance requirements.....	27
8.4	Environmental performance requirements.....	32
	Annex A (normative) Adaptor matched reference plug details	35
	Annex B (informative) Reference connector details	36
	Annex C (normative) Sample size and product sourcing requirements	37
	Bibliography	38
	Figure 1 - Outline dimensions - Plug	11
	Figure 2 - Outline dimensions - Adaptor.....	12
	Figure 3 - Mating face and other limit dimensions - Plug.....	15
	Figure 4 - Ferrule end face geometry - After termination.....	17
	Figure 5 - Positioning of fibre core.....	18
	Figure 6 - Ferrule end face geometry - Allowable undercut.....	19
	Figure 7 - Requirements for the attenuation grades for the plug fibre core connected to the ideal reference.....	20
	Figure 8 - Mating face and other dimensions - Adaptor.....	21
	Figure 9 - Pin gauge for adaptor	23
	Table 1 - Ensured level of random attenuation	5
	Table 2 - Preferred colour scheme.....	8
	Table 3 - Plug variants	9
	Table 4 - Adaptor variants.....	10
	Table 5 - Geometrical parameters.....	18
	Table 6 - Optical performance requirements.....	25
	Table 7 - Mechanical performance requirements	27
	Table 8 - Environmental performance requirements	32

This is a free preview. Purchase the entire publication at the link below:

[Product Page](#)

-
- [Looking for additional Standards? Visit Intertek Inform Infostore](#)
 - [Learn about LexConnect, All Jurisdictions, Standards referenced in Australian legislation](#)
-