



**NSAI**  
Standards

Irish Standard  
I.S. EN 61029-2-4:2011

Safety of transportable motor-operated electric tools -- Part 2-4: Particular requirements for bench grinders (IEC 61029-2-4:1993 (MOD) + A1:2001 (MOD))

**I.S. EN 61029-2-4:2011**

*Incorporating amendments/corrigenda issued since publication:*

The National Standards Authority of Ireland (NSAI) produces the following categories of formal documents:

I.S. xxx: Irish Standard – national specification based on the consensus of an expert panel and subject to public consultation.

S.R. xxx: Standard Recommendation - recommendation based on the consensus of an expert panel and subject to public consultation.

SWiFT xxx: A rapidly developed recommendatory document based on the consensus of the participants of an NSAI workshop.

<p><i>This document replaces:</i> EN 61029-2-4:2003 <input type="checkbox"/> corr. Apr.2003 <input type="checkbox"/> A1:2003</p>	<p><i>This document is based on:</i> EN 61029-2-4:2011</p>	<p><i>Published:</i> 28 January, 2011</p>
--	--	---

<p>This document was published under the authority of the NSAI and comes into effect on:</p> <p style="text-align: center;">14 February, 2011</p>	<p>ICS number: 25.140.20 25.080.50</p>
---	--

<p><b>NSAI</b> 1 Swift Square, Northwood, Santry Dublin 9</p>	<p>T <input type="checkbox"/> 353 1 807 3800 F <input type="checkbox"/> 353 1 807 3838 E standards <input type="checkbox"/> nsai.ie <b>W NSAI.ie</b></p>	<p><b>Sales:</b> T <input type="checkbox"/> 353 1 857 6730 F <input type="checkbox"/> 353 1 857 6729 W standards.ie</p>
---	--	---

dar  s um Chaighde  in N  isi  nta na h  ireann

EUROPEAN STANDARD  
NORME EUROPÉENNE  
EUROPÄISCHE NORM

**EN 61029-2-4**

January 2011

ICS 25.140.20; 25.080.50

Supersedes EN 61029-2-4:2003 + corr. Apr.2003 + A1:2003

English version

**Safety of transportable motor-operated electric tools -  
Part 2-4: Particular requirements for bench grinders**  
(IEC 61029-2-4:1993, modified + A1:2001, modified)

Sécurité des machines-outils  
électriques semi-fixes -  
Partie 2-4: Règles particulières pour les  
tourements à meuler  
(CEI 61029-2-4:1993, modifiée +  
A1:2001, modifiée)

Sicherheit transportabler  
motorbetriebener Elektrowerkzeuge -  
Teil 2-4: Besondere Anforderungen für  
Tischschleifmaschinen  
(IEC 61029-2-4:1993, modifiziert +  
A1:2001, modifiziert)

This European Standard was approved by CENELEC on 2011-01-10. CENELEC members are bound to comply with the CEN/CENELEC Internal Regulations which stipulate the conditions for giving this European Standard the status of a national standard without any alteration.

Up-to-date lists and bibliographical references concerning such national standards may be obtained on application to the Central Secretariat or to any CENELEC member.

This European Standard exists in three official versions (English, French, German). A version in any other language made by translation under the responsibility of a CENELEC member into its own language and notified to the Central Secretariat has the same status as the official versions.

CENELEC members are the national electrotechnical committees of Austria, Belgium, Bulgaria, Croatia, Cyprus, the Czech Republic, Denmark, Estonia, Finland, France, Germany, Greece, Hungary, Iceland, Ireland, Italy, Latvia, Lithuania, Luxembourg, Malta, the Netherlands, Norway, Poland, Portugal, Romania, Slovakia, Slovenia, Spain, Sweden, Switzerland and the United Kingdom.

## CENELEC

European Committee for Electrotechnical Standardization  
Comité Européen de Normalisation Electrotechnique  
Europäisches Komitee für Elektrotechnische Normung

**Management Centre: Avenue Marnix 17, B - 1000 Brussels**

## Foreword

The text of the International Standard IEC 61029-2-4:1993 + A1:2001, prepared by IEC TC 116, Safety of hand-held motor-operated electric tools, together with the common modifications prepared by the Technical Committee CENELEC TC 116, Safety of motor-operated electric tools, was submitted to the formal vote and was approved by CENELEC as EN 61029-2-4 on 2011-01-10.

This document supersedes EN 61029-2-4:2003 + corrigendum April 2003 + A1:2003.

The following dates were fixed:

- latest date by which the EN has to be implemented at national level by publication of an identical national standard or by endorsement (dop) 2012-01-10
- latest date by which the national standards conflicting with the EN have to be withdrawn (dow) 2014-01-10

In this document, the common modifications to the International Standard are indicated by a vertical line in the left margin of the text.

This European Standard is divided into two parts:

Part 1 General requirements which are common to most transportable electric motor operated tools (for the purpose of this standard referred to simply as tools) which could come within the scope of this standard;

Part 2 Requirements for particular types of tool which either supplement or modify the requirements given in part 1 to account for the particular hazards and characteristics of these specific tools.

This European Standard has been prepared under a mandate given to CENELEC by the European Commission and the European Free Trade Association and covers essential requirements of the Machinery Directive 2006/42/EC. See Annex ZZ.

Compliance with the relevant clauses of Part 1 together with this Part 2 provides one means of conforming with the specified essential health and safety requirements of the Directive.

For noise and vibration this standard covers the requirements for their measurement, the provision of information arising from these measurements and the provision of information about the personal protective equipment required. Specific requirements for the reduction of the risk arising from noise and vibration through the design of the tool are not given as this reflects the current state of the art.

As with any standard, technical progress will be kept under review so that any developments can be taken into account.

**Warning:** Other requirements and other EC Directives can be applicable to the products falling within the scope of this standard.

Part 2-4 is to be used in conjunction with EN 61029-1:2009.

Part 2-4 supplements or modifies the corresponding clauses of EN 61029-1, so as to convert it into the European Standard: Safety requirements for transportable bench grinders.

Where a particular subclause of Part 1 is not mentioned in this Part 2-4, that subclause applies as far as is reasonable. Where this Part 2-4 states "addition", "modification" or "replacement", the relevant text of Part 1 is to be adapted accordingly.

Subclauses, tables and figures which are additional to those in Part 1 are numbered starting from 101. Subclauses, tables and figures which are additional to those in IEC 61029-2-4 are prefixed "Z".

NOTE In this European Standard the following print types are used:

- Requirements proper;
- *Test specifications*;
- Explanatory matter.

## Contents

1	Scope .....	6
2	Terms and definitions .....	6
3	General requirement .....	7
4	General notes on tests .....	7
5	Rating .....	7
6	Classification .....	7
7	Marking .....	7
8	Protection against electric shock .....	8
9	Starting .....	8
10	Input and current .....	8
11	Heating .....	8
12	Leakage current .....	8
13	Environmental requirements .....	9
14	Protection against ingress of foreign bodies and moisture resistance .....	9
15	Insulation resistance and electric strength .....	9
16	Endurance .....	9
17	Abnormal operation .....	9
18	Stability and mechanical hazards .....	9
19	Mechanical strength .....	15
20	Construction .....	15
21	Internal wiring .....	15
22	Components .....	15
23	Supply connection and external flexible cables and cords .....	15
24	Terminals for external conductors .....	15
25	Provision for earthing .....	16
26	Screws and connections .....	16
27	Creepage distances, clearances and distance through insulation .....	16
28	Resistance to heat, fire and tracking .....	16
29	Resistance to rusting .....	16
30	Radiation .....	16

## Figures

Figure 101	– Bench grinder .....	17
Figure 102	– Schema .....	18
Figure 103	– Guard .....	19
Figure 104	– Bench grinder equipped with straight-sided cup wheels .....	20
Figure 105	– Bench grinder with inclinable work rest .....	21
Figure 106	– Transparent screen .....	21
Figure 107	– Combined bench grinder .....	22
Figure 108	– Flange dimensions .....	23
Figure 109	– Protection of the rotating shaft .....	23

Figure Z101 – Mechanical strength.....	24
Figure Z102 – Guard for brush .....	24

**Tables**

Table Z101 – Guard thickness for steel .....	10
Table Z102 – Guard thickness for aluminium .....	10
Table Z103 – Material specifications .....	11
Table 101 – Flange dimensions (see Figure 108).....	13
Table Z104 – Test torque for flanges.....	13

## Text of EN 61029-2-4

The text of this European Standard consists of the text of the International Standard IEC 61029-2-4:1993 + A1:2001 with the following common modifications.

### COMMON MODIFICATIONS

#### 1 Scope

This clause of Part 1 is applicable except as follows:

##### 1.1 *Addition:*

This standard applies to transportable bench grinders (see Figure 101) and combined bench grinders (see Figure 107) with a wheel diameter and brush diameter not exceeding 200 mm, a thickness not exceeding 30 mm and a peripheral speed not exceeding 50 m/s, as defined in 2.101 and 2.107.

The requirements for bonded abrasive products (wheel) are given in EN 12413. The requirements for brushes are given in EN 1083-2.

Stationary grinding machines are covered by EN 13218.

Bench grinders where the wheel partly runs in a water reservoir are not considered as tools with water supply.

#### 2 Terms and definitions

This clause of Part 1 is applicable except as follows:

##### 2.21

###### **normal load**

the load to obtain rated input

##### 2.101

###### **bench grinder**

tool designed to grind metal or similar materials by means of one or two rotating abrasive wheels fixed on the tool spindle, the work piece being held by hand (see Figure 101)

##### 2.102

###### **accessory**

device or piece other than a grinding wheel intended to be mounted on the bench grinder spindle

##### 2.103

###### **tool spindle**

motor spindle of the bench grinder or of the combined bench grinder which supports the brush and/or grinding wheels and transports the rotation to them

##### 2.104

###### **guard for wheel**

device which partially encloses the abrasive wheel in order to protect the user against accidental contact with the wheel in normal use and against ejection of fragments of the wheel in the protected area in case of breakage of the wheel



## SOMMAIRE

	Pages
AVANT-PROPOS .....	4
Articles	
1 Domaine d'application .....	6
2 Définitions .....	6
3 Prescription générale .....	8
4 Généralités sur les essais .....	10
5 Caractéristiques nominales .....	10
6 Classification .....	10
7 Marques et indications .....	10
8 Protection contre les chocs électriques .....	12
9 Démarrage .....	12
10 Puissance et courant .....	12
11 Echauffements .....	12
12 Courant de fuite .....	12
13 Réduction des perturbations de radiodiffusion et de télévision .....	12
14 Protection contre l'introduction de corps étrangers et résistance à l'humidité .....	12
15 Résistance d'isolement et rigidité diélectrique .....	12
16 Endurance .....	12
17 Fonctionnement anormal .....	12
18 Stabilité et dangers mécaniques .....	14
19 Résistance mécanique .....	26
20 Construction .....	28
21 Conducteurs internes .....	28
22 Eléments constitutants .....	28
23 Raccordement au réseau et câbles souples extérieurs .....	28
24 Bornes pour conducteurs externes .....	28
25 Dispositions en vue de la mise à la terre .....	28
26 Vis et connexions .....	28
27 Lignes de fuite, distances dans l'air et distances à travers l'isolation .....	28
28 Résistance à la chaleur, au feu et aux courants de cheminement .....	28
29 Protection contre la rouille .....	28
30 Rayonnements .....	28
Annexes .....	30

## CONTENTS

	Page
FOREWORD .....	5
Clause	
1 Scope .....	7
2 Definitions .....	7
3 General requirement .....	9
4 General notes on tests .....	11
5 Rating .....	11
6 Classification .....	11
7 Marking .....	11
8 Protection against electric shock .....	13
9 Starting .....	13
10 Input and current .....	13
11 Heating .....	13
12 Leakage current .....	13
13 Radio and television interference suppression .....	13
14 Protection against ingress of foreign bodies and moisture resistance .....	13
15 Insulation resistance and electric strength .....	13
16 Endurance .....	13
17 Abnormal operation .....	13
18 Stability and mechanical hazards .....	15
19 Mechanical strength .....	27
20 Construction .....	29
21 Internal wiring .....	29
22 Components .....	29
23 Supply connection and external flexible cables and cords .....	29
24 Terminals for external conductors .....	29
25 Provision for earthing .....	29
26 Screws and connections .....	29
27 Creepage distances, clearances and distances through insulation .....	29
28 Resistance to heat, fire and tracking .....	29
29 Resistance to rusting .....	29
30 Radiation .....	29
Annexes .....	31

## COMMISSION ÉLECTROTECHNIQUE INTERNATIONALE

## SÉCURITÉ DES MACHINES-OUTILS ÉLECTRIQUES SEMI-FIXES

## Partie 2: Règles particulières pour les tourets à meuler

## AVANT-PROPOS

- 1) La CEI (Commission Electrotechnique Internationale) est une organisation mondiale de normalisation composée de l'ensemble des comités électrotechniques nationaux (Comités nationaux de la CEI). La CEI a pour objet de favoriser la coopération internationale pour toutes les questions de normalisation dans les domaines de l'électricité et de l'électronique. A cet effet, la CEI, entre autres activités, publie des Normes internationales. Leur élaboration est confiée à des comités d'études, aux travaux desquels tout Comité national intéressé par le sujet traité peut participer. Les organisations internationales, gouvernementales et non gouvernementales, en liaison avec la CEI, participent également aux travaux. La CEI collabore étroitement avec l'Organisation Internationale de Normalisation (ISO), selon des conditions fixées par accord entre les deux organisations.
- 2) Les décisions ou accords officiels de la CEI en ce qui concerne les questions techniques, préparés par les comités d'études où sont représentés tous les Comités nationaux s'intéressant à ces questions, expriment dans la plus grande mesure possible un accord international sur les sujets examinés.
- 3) Ces décisions constituent des recommandations internationales publiées sous forme de normes, de rapports techniques ou de guides et agréées comme telles par les Comités nationaux.
- 4) Dans le but d'encourager l'unification internationale, les Comités nationaux de la CEI s'engagent à appliquer de façon transparente, dans toute la mesure possible, les Normes internationales de la CEI dans leurs normes nationales et régionales. Toute divergence entre la norme de la CEI et la norme nationale ou régionale correspondante doit être indiquée en termes clairs dans cette dernière.

La présente partie de la Norme internationale CEI 1029 a été établie par le sous-comité 61F: Sécurité des outils électroportatifs à moteur, du comité d'études 61 de la CEI: Sécurité des appareils électrodomestiques et analogues.

Le texte de cette partie est issu des documents suivants:

DIS	Rapport de vote
61F(BC)91	61F(BC)99

Le rapport de vote indiqué dans le tableau ci-dessus donne toute information sur le vote ayant abouti à l'approbation de cette partie.

La présente partie 2 doit être utilisée conjointement avec la première édition de la CEI 1029-1.

La présente partie 2 complète ou modifie les articles correspondants de la CEI 1029-1 de façon à la transformer en norme CEI: Règles de sécurité pour les tourets à meuler semi-fixes.

Lorsqu'un paragraphe particulier de la première partie n'est pas mentionné dans cette partie 2, ce paragraphe s'applique pour autant qu'il est raisonnable. Lorsque la présente norme spécifie «addition», «modification» ou «remplacement», le texte correspondant de la première partie doit être adapté en conséquence.

## NOTES

1 Les caractères d'imprimerie suivants sont employés:

- prescriptions: caractères romains;
- *modalités d'essai: caractères italiques;*
- notes: petits caractères romains;

Les termes définis à l'article 2 figurent en caractères gras.

2 Les paragraphes, notes et les figures complémentaires à ceux de la première partie, sont numérotés à partir de 101.

## INTERNATIONAL ELECTROTECHNICAL COMMISSION

## SAFETY OF TRANSPORTABLE MOTOR-OPERATED ELECTRIC TOOLS

## Part 2: Particular requirements for bench grinders

## FOREWORD

- 1) The IEC (International Electrotechnical Commission) is a worldwide organization for standardization comprising all national electrotechnical committees (IEC National Committees). The object of the IEC is to promote international cooperation on all questions concerning standardization in the electrical and electronic fields. To this end and in addition to other activities, the IEC publishes International Standards. Their preparation is entrusted to technical committees; any IEC National Committee interested in the subject dealt with may participate in this preparatory work. International, governmental and non-governmental organizations liaising with the IEC also participate in this preparation. The IEC collaborates closely with the International Organization for Standardization (ISO) in accordance with conditions determined by agreement between the two organizations.
- 2) The formal decisions or agreements of the IEC on technical matters, prepared by technical committees on which all the National Committees having a special interest therein are represented, express, as nearly as possible, an international consensus of opinion on the subjects dealt with.
- 3) They have the form of recommendations for international use published in the form of standards, technical reports or guides and they are accepted by the National Committees in that sense.
- 4) In order to promote international unification, IEC National Committees undertake to apply IEC International Standards transparently to the maximum extent possible in their national and regional standards. Any divergence between the IEC Standard and the corresponding national or regional standard shall be clearly indicated in the latter.

This part of International Standard IEC 1029 has been prepared by subcommittee 61F: Safety of hand-held motor-operated electric tools, of IEC technical committee 61: Safety of household and similar electrical appliances.

The text of this part is based on the following documents:

DIS	Report on Voting
61F(CO)91	61F(CO)99

Full information on the voting for the approval of this part can be found in the report on voting indicated in the above table.

This part 2 is to be used in conjunction with the first edition of IEC 1029-1.

This part 2 supplements or modifies the corresponding clauses in IEC 1029-1, so as to convert it into the IEC Standard: Safety requirements for transportable bench grinders.

Where a particular subclause of part 1 is not mentioned in this part 2, that subclause applies as far as is reasonable. Where this standard states "addition", "modification" or "replacement", the relevant text in part 1 is to be adapted accordingly.

## NOTES

1 The following print types are used:

- requirements: in roman type;
- *test specifications: in italic type;*
- notes: in small roman type

The terms defined in clause 2 are printed in **bold typeface**.

2 Subclauses, notes and figures which are additional to those in part 1 are numbered starting from 101.

## SÉCURITÉ DES MACHINES-OUTILS ÉLECTRIQUES SEMI-FIXES

### Partie 2: Règles particulières pour les tourets à meuler

#### 1 Domaine d'application

L'article de la première partie est applicable avec l'exception suivante:

##### 1.1 Modification:

Remplacer le premier alinéa par:

La présente Norme internationale s'applique aux tourets à meuler semi-fixes dont la meule a un diamètre maximal de 200 mm et une vitesse circonférentielle maximale de 50 m/s, comme cela est spécifié en 2.101.

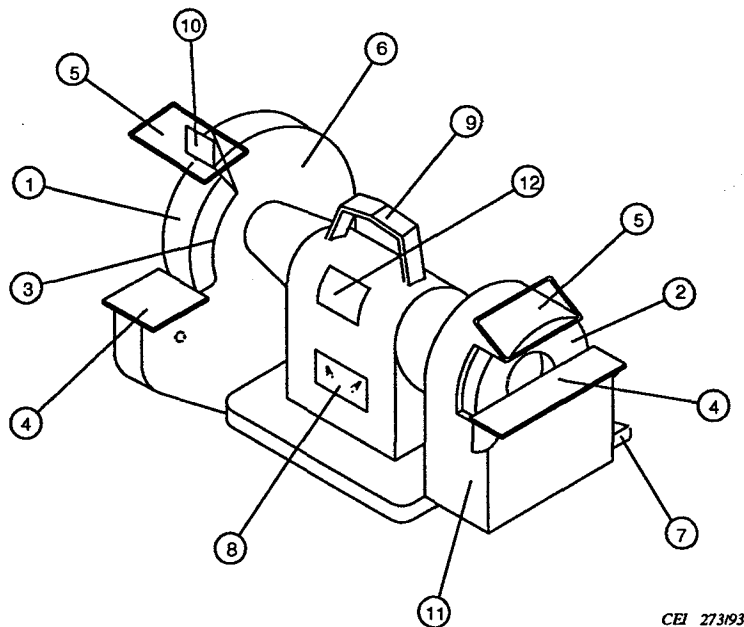

CEI 273193

- |  |   |
|--|---|
| 1 = meule plate                                | 7 = buse d'aspiration de poussière                  |
| 2 = meule lapidaire                            | 8 = dispositif de marche arrêt                      |
| 3 = bride                                      | 9 = poignée   |
| 4 = dispositif de maintien de pièces           | 10 = pare-étincelles                                |
| 5 = écran transparent                          | 11 = dispositif de protection de la meule lapidaire |
| 6 = dispositif de protection de la meule plate | 12 = plaque signalétique                            |

Figure 101 – Touret à meuler

NOTE - Le schéma est uniquement fourni à titre indicatif.

#### 2 Définitions

L'article de la première partie est applicable avec les exceptions suivantes:

##### 2.21 Remplacement:

**charge normale:** Charge obtenue quand l'outil fonctionne d'une façon continue, le couple appliqué à l'axe étant tel que la puissance absorbée, en watts, soit égale à la puissance nominale.

## SAFETY OF TRANSPORTABLE MOTOR-OPERATED ELECTRIC TOOLS

### Part 2: Particular requirements for bench grinders

#### 1 Scope

This clause of part 1 is applicable except as follows:

##### 1.1 Modification:

Replace the first paragraph by:

This International Standard applies to transportable bench grinders with a wheel diameter not exceeding 200 mm and a peripheral speed not exceeding 50 m/s, as defined in 2.101.

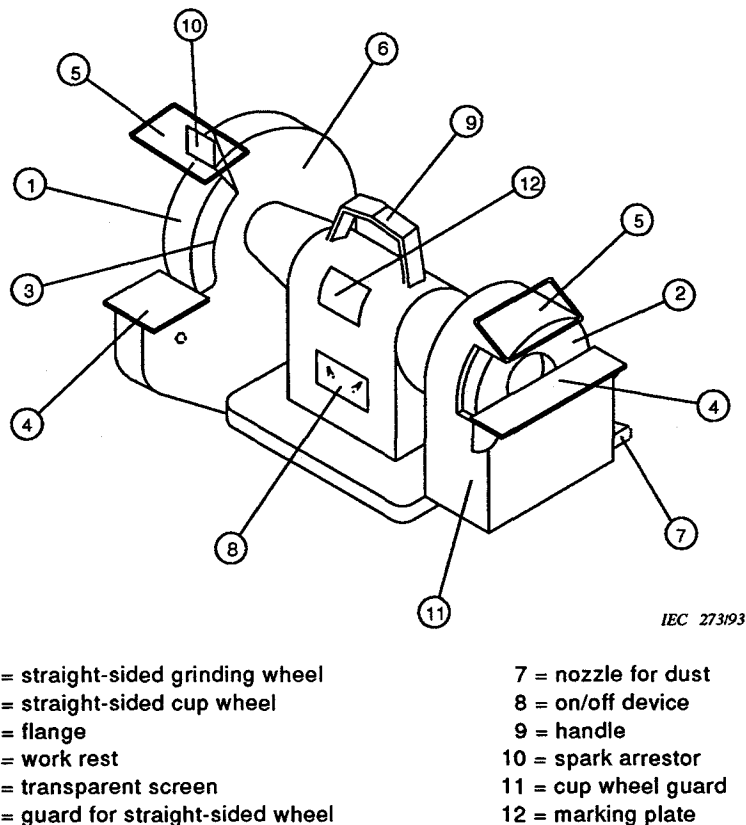

Figure 101 – Bench grinder

NOTE - The drawing is given as a guide only.

#### 2 Definitions

This clause of part 1 is applicable except as follows:

##### 2.21 Replacement:

**normal load:** Load obtained when the tool is operated continuously, the torque applied to the spindle being such that the input, in watts, is equal to the rated input.

This is a free preview. Purchase the entire publication at the link below:

[Product Page](#)

- 
- [Looking for additional Standards? Visit Intertek Inform Infostore](#)
  - [Learn about LexConnect, All Jurisdictions, Standards referenced in Australian legislation](#)
-