



NSAI
Standards

Irish Standard
I.S. EN 50408:2008

Household and similar electrical appliances - Safety - Particular requirements for cab heaters for vehicles

I.S. EN 50408:2008

Incorporating amendments/corrigenda issued since publication:

EN 50408:2008/A1:2011

The National Standards Authority of Ireland (NSAI) produces the following categories of formal documents:

I.S. xxx: Irish Standard – national specification based on the consensus of an expert panel and subject to public consultation.

S.R. xxx: Standard Recommendation - recommendation based on the consensus of an expert panel and subject to public consultation.

SWiFT xxx: A rapidly developed recommendatory document based on the consensus of the participants of an NSAI workshop.

<i>This document replaces:</i>	<i>This document is based on:</i> EN 50408:2008	<i>Published:</i> 29 August, 2008
This document was published under the authority of the NSAI and comes into effect on: 28 October, 2008		ICS number: 43.040.60
NSAI 1 Swift Square, Northwood, Santry Dublin 9	T +353 1 807 3800 F +353 1 807 3838 E standards@nsai.ie W NSAI.ie	Sales: T +353 1 857 6730 F +353 1 857 6729 W standards.ie
Údarás um Chaighdeáin Náisiúnta na hÉireann		

EUROPEAN STANDARD
NORME EUROPÉENNE
EUROPÄISCHE NORM

EN 50408/A1

September 2011

ICS 43.040.60

English version

**Household and similar electrical appliances -
Safety -
Particular requirements for cab heaters for vehicles**

Appareils électrodomestiques et
analogues -
Sécurité -
Règles particulières pour les appareils de
chauffage d'habitacles de véhicules

Sicherheit elektrischer Geräte für den
Hausgebrauch und ähnliche Zwecke -
Besondere Anforderungen für
Fahrzeugkabinenheizungen

This amendment A1 modifies the European Standard EN 50408:2008; it was approved by CENELEC on 2011-04-25. CENELEC members are bound to comply with the CEN/CENELEC Internal Regulations which stipulate the conditions for giving this amendment the status of a national standard without any alteration.

Up-to-date lists and bibliographical references concerning such national standards may be obtained on application to the Central Secretariat or to any CENELEC member.

This amendment exists in three official versions (English, French, German). A version in any other language made by translation under the responsibility of a CENELEC member into its own language and notified to the Central Secretariat has the same status as the official versions.

CENELEC members are the national electrotechnical committees of Austria, Belgium, Bulgaria, Croatia, Cyprus, the Czech Republic, Denmark, Estonia, Finland, France, Germany, Greece, Hungary, Iceland, Ireland, Italy, Latvia, Lithuania, Luxembourg, Malta, the Netherlands, Norway, Poland, Portugal, Romania, Slovakia, Slovenia, Spain, Sweden, Switzerland and the United Kingdom.

CENELEC

European Committee for Electrotechnical Standardization
Comité Européen de Normalisation Electrotechnique
Europäisches Komitee für Elektrotechnische Normung

Management Centre: Avenue Marnix 17, B - 1000 Brussels

Foreword

This amendment to the European Standard EN 50408:2008 was prepared by the Technical Committee CENELEC TC 61, Safety of household and similar electrical appliances (cf. document CLC/TC61(SE)0406, discussed during the Brussels meeting of CLC/TC 61 in July 2010).

The text of the draft was submitted to the Unique Acceptance Procedure and was approved by CENELEC as Amendment A1 to EN 50408:2008 on 2011-04-25.

Attention is drawn to the possibility that some of the elements of this document may be the subject of patent rights. CEN and CENELEC shall not be held responsible for identifying any or all such patent rights.

The following dates were fixed:

- latest date by which the amendment has to be implemented at national level by publication of an identical national standard or by endorsement (dop) 2012-04-25
 - latest date by which the national standards conflicting with the amendment have to be withdrawn (dow) 2014-04-25
-

Text of A1 to EN 50408:2008

11 Heating

Replace Figure Z201 by the following figure.

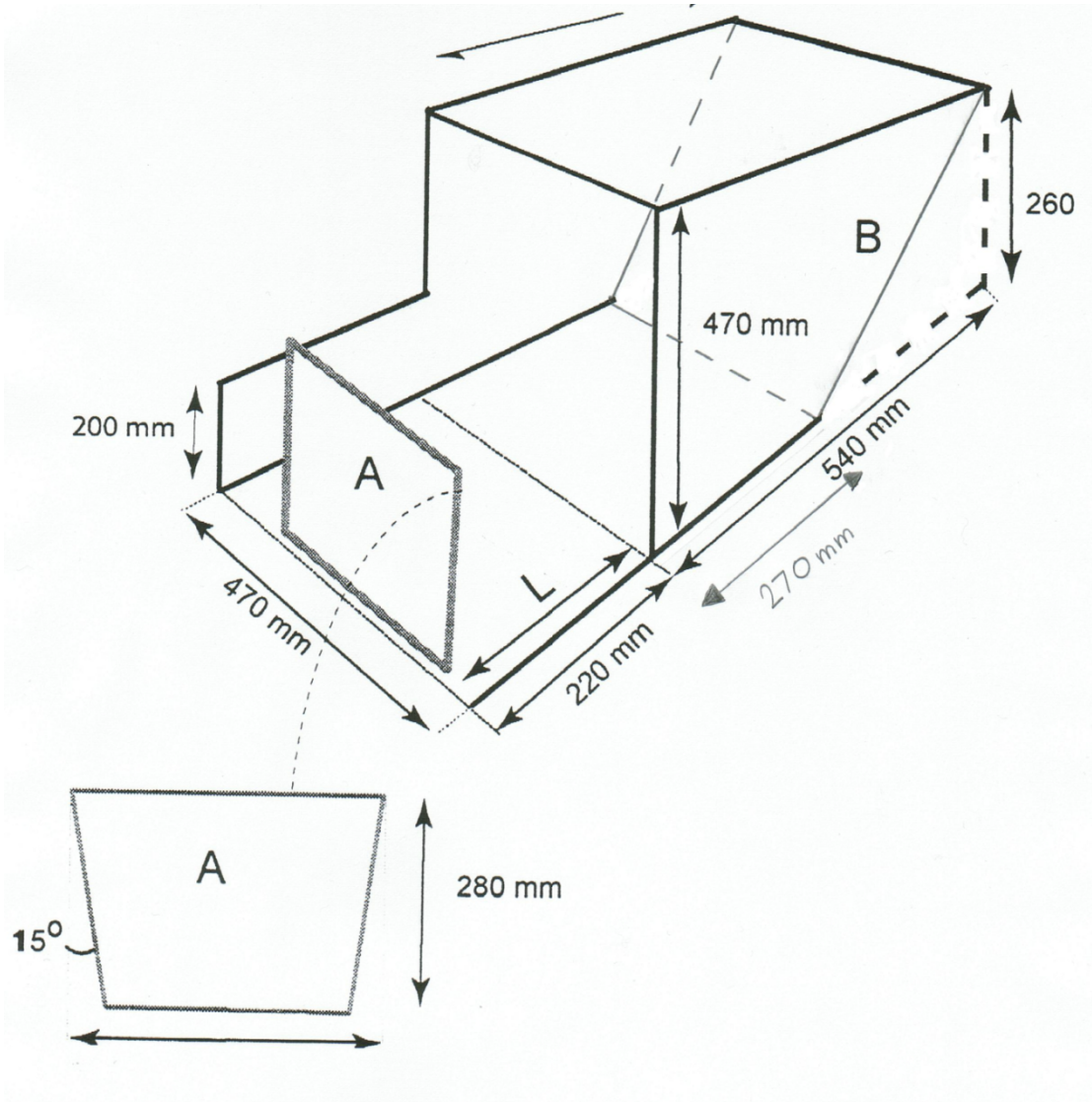

This page is intentionally left BLANK.

ICS 43.040.60

English version

**Household and similar electrical appliances -
Safety -
Particular requirements for cab heaters for vehicles**

Appareils électrodomestiques
et analogues -
Sécurité -
Règles particulières pour les appareils
de chauffage d'habitacles de véhicules

Sicherheit elektrischer Geräte
für den Hausgebrauch
und ähnliche Zwecke -
Besondere Anforderungen
für Fahrzeugkabinenheizungen

This European Standard was approved by CENELEC on 2008-04-16. CENELEC members are bound to comply with the CEN/CENELEC Internal Regulations which stipulate the conditions for giving this European Standard the status of a national standard without any alteration.

Up-to-date lists and bibliographical references concerning such national standards may be obtained on application to the Central Secretariat or to any CENELEC member.

This European Standard exists in three official versions (English, French, German). A version in any other language made by translation under the responsibility of a CENELEC member into its own language and notified to the Central Secretariat has the same status as the official versions.

CENELEC members are the national electrotechnical committees of Austria, Belgium, Bulgaria, Cyprus, the Czech Republic, Denmark, Estonia, Finland, France, Germany, Greece, Hungary, Iceland, Ireland, Italy, Latvia, Lithuania, Luxembourg, Malta, the Netherlands, Norway, Poland, Portugal, Romania, Slovakia, Slovenia, Spain, Sweden, Switzerland and the United Kingdom.

CENELEC

European Committee for Electrotechnical Standardization
Comité Européen de Normalisation Electrotechnique
Europäisches Komitee für Elektrotechnische Normung

Central Secretariat: rue de Stassart 35, B - 1050 Brussels

I.S. EN 50408:2008

EN 50408:2008

- 2 -

Foreword

This European Standard was prepared by CENELEC BTWG 100-1, Cab heaters for vehicles.

The text of the draft was submitted to the formal vote and was approved by CENELEC as EN 50408 on 2008-04-16.

The following dates were fixed:

- latest date by which the EN has to be implemented at national level by publication of an identical national standard or by endorsement (dop) 2009-05-01
- latest date by which the national standards conflicting with the EN have to be withdrawn (dow) 2011-05-01

This European Standard is to be used together with EN 60335-2-30, Household and similar electrical appliances - Safety - Part 2-30: Particular requirements for room heaters. It was established on the basis of EN 60335-2-30:2003, which is to be used together with EN 60335-1:2002. Amendments and revisions of EN 60335-1 and EN 60335-2-30 have also to be taken into account and the dates when such changes become applicable will be stated in the relevant amendment or revision of these standards.

This standard supplements or modifies the corresponding clauses of EN 60335-2-30, so as to convert it into the European Standard: Safety requirements for cab heaters for vehicles.

NOTE 1 The following numbering system is used:

- subclauses, notes, tables and figures that are numbered starting from 101 are additional to those in EN 60335-1;
- subclauses, notes, tables and figures that are additional to those in EN 60335-2-30 are numbered starting from 201 and are prefixed with the letter Z;
- additional annexes to those in EN 60335-2-30 are lettered AAA, BBB, etc.

NOTE 2 The following print types are used:

- requirements: in roman type;
- *test specifications: in italic type;*
- notes: in small roman type.

Words in **bold** in the text are defined in Clause 3. When a definition concerns an adjective, the adjective and the associated noun are also in bold.

This is a free preview. Purchase the entire publication at the link below:

[Product Page](#)

-
- [Looking for additional Standards? Visit Intertek Inform Infostore](#)
 - [Learn about LexConnect, All Jurisdictions, Standards referenced in Australian legislation](#)
-